

# THE REFLECTOR

Newsletter of the Palomar Model A Ford Club  
February, 2024 : Volume 52, Number 2

## TOUR REVIEW SO TOUR CAN BE REVIEWED

On Saturday, January sixth five members met to try their hand at miniature golfing and as you can see by the photos, it was a beautiful day despite the number of folks who called in sick (a total of four cars-worth).

Being one of those who missed, I can only guess that the majority of those who did make it were intimidated by the energy and confidence of Rick Spinello bringing his lucky putter, and so they decided to skip the golf and just enjoy the drive and the friendship. They took a meandering route to The Rib Shack over by Nessy Burger off the 395. Which had killer food, by the way.

As a result of the plan change, the February tenth tour still has an opening for miniature golf up in Murietta at the Mulligan Family Fun Center. It's at 24950 Madison Ave., and the drive shouldn't take long, even on backroads, so the plan is to meet at Palomar Estates at 10:30, leave at 11:00 and folks not planning to drive with us, to meet there at noon. See additional plans on page 9 of this issue.





# ***PRESIDENT'S MESSAGE***

My first month as club president was a whirlwind. We have a new meeting location and time, we've updated some of the raffle protocols to follow state laws, we've set up monthly breakfasts in order to bring up the level of fun and participation, we've approved donations in excess of \$500 that will allow for growing the hobby, and we have plans for two summer picnics on either side of our wide territory. Besides that, the majority of our previous members have renewed and our offices are filled. What should we try next?

Since I took a couple of blacksmithing classes before my auto mechanics ones, I know the meaning of having too many irons in the fire and how by collecting resources beforehand, managing the help of a team, imagining outcomes, and having plans that take simple steps to increase the productivity of the forge, there won't actually be too many irons. It's really not rocket science being president of a club like ours. Actually, any volunteer office there is would allow you lots of flexibility in order to insure success. We're more like a family that way.

I bring this up because I would really like someone to step up to act as breakfast organizer. (or lunch, dinner, or late evening drinks and dancing organizer [or would the office be choreographer?], even). I can even imagine the slogan "Come and Drive your Model A to Dance the Night Away."

I've seen clubs that have a Men's Night and a Lady's Night. I've seen clubs that have a Sewing Circle for people who want to make era clothing to wear when they drive their cars. I've seen car shows, races, show-and-tell days with kids including lessons on how to start them. I've seen parades, swap meets, poker nights, and garage clean outs. I've seen classes in order to learn judging standards, tech seminars, and safety checks, and those are all of the things we could easily copy.

I would be so proud of us if we chose a stretch of a historic highway in San Diego County and we became politically active to preserve it. That would be highways 101, 395, and in south county highway 80. We could also look to drive to and take photos of our Model A's at old gas stations before they're torn down. Escondido has them at 555 and 1404 South Escondido Blvd. 108 North Kalmia and the Deer Park Winery. I believe Oceanside has one or two buildings that used to house car dealerships before they moved to Carlsbad. Popular sites for car shows, including Pepper Tree Frosty Burger Run, The Fallbrook (High School) Vintage Car Show, and the EHS Memorial Day Car Show in Grapeday Park have each been stopped. We all know how the City of Orange has hassled the OC MAFCA Chapter, so what's next, Cruisin' Grand? The Wavecrest Woodie Meet at Moonlight State Beach? The best time to support classic car infrastructure is before developers, bureaucrats, and the ravages of time come up with ways to change things to their own advantage. If not us, who? If not now, when?

May your tank be full and the road opened in front of you.

David Frazee, President Pa

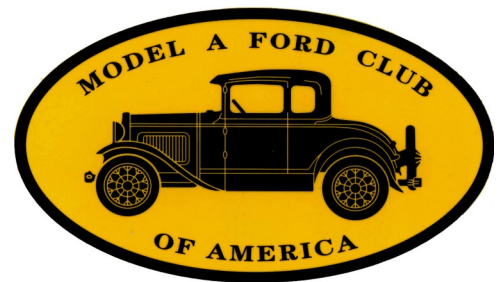

# *JANUARY MINUTES*

Minutes from January 3, 2024 – The new [temporary] location for meetings is at the Vista Library, 700 Eucalyptus along with a new time of 4:30 PM. Meeting of the Palomar A's was called to order by President, David Frazee at 4:35 PM with 35 in attendance. This included 2 guests: David Stinson and his son Liam. David owns 2 Model A's, a 1930-31 4 door and a 1931 Soft Top Pickup.

A motion was made and approved to accept the minutes of the November meeting with no changes.

Treasurer's Report – Bruce Furbush gave the treasurer's report and indicated there were a few people that had not yet paid their 2024 dues. Motion was made and approved to accept the report and pay any outstanding bills.

There was discussion of flowers or a gift to Jesse Greenlee, Mark's daughter, for setting up the new website in Squarespace. For now the discussion is tabled pending additional information.

Sunshine & Sorrow – Regarding deaths of established Club members, existing procedure has been \$100 donation to a charity in the person's name and/or a remembrance brick is purchased and set at the Model A Museum in Gilmore, Michigan.

Nancy Peterson [October 11, 2023] & husband Peter Peterson [December 24, 2023] will be sharing 1 brick. There will be 1 brick each for Carla Dembsky Hibbard [Sept 17, 2023] and for Richard Allen [December 10, 2023]. The remembrance bricks are \$150 each so it was voted for a one time increase of \$50 to cover the 3 bricks.

Alternate Gatherings – David Frazee suggested alternate or additional get togethers to encourage more socializing and participation among other Model A group members. One option is "last Sunday breakfasts" As the name implies, they would happen on the last Sunday of the month and in different locations. These would be very casual gatherings that would allow interaction often not possible during regular Club meetings. The initial meeting is 8:00 AM on Jan 28 at the Main Street Cafe, 507 S. Main St. in Fallbrook. He also asked for input for any other locations and possibly a volunteer to schedule them.

Along the same lines, the June Club Meeting will be held at Old Poway Park and the July Meeting will be at San Dieguito Park. Dates to be announced later. They both will be pot-luck. Bring a covered dish. The Club will provide hamburgers & hot dogs. Encourage members from other Model A Clubs to attend.

Short Tours – Mark Greenlee reported that the original Fleet Week tour on November 11 was changed to an impromptu visit with Fred Slikker by David Frazee, Rick Spinello, and himself. There was also discussion of a trip to Murietta on Jan. 6 for miniature golf.

Long Tours – Bruce Howe gave an overview of the upcoming CCRG Jamboree tour to Clovis, March 7th through 11th. For more details email Bruce [zumaque42@yahoo.com] or Jeanette [jeanettedmop@yahoo.com]

Also discussed was the April 21 Orange County Pancake Breakfast, the Paradise Valley Model A Swap Meet in San Bernadino and the Motor Transport Museum in Campo.



# ***JANUARY MINUTES CONTINUED***

Miscellaneous – Bruce Furbush provided information regarding embroidery of the club logo either on a patch that may be sewn on separately or as direct stitch onto a jacket. Pricing for different options are varied. If interested contact Judy's Embroidery – 760-741-2292 or [www.judysembroidery.com](http://www.judysembroidery.com)

The MAFCA Museum is taking donations towards expansion. Personalized bricks at \$150 each and plaques at \$200 are being offered. Other levels of participation exist. Order form and additional information can be found in "The 'A' Preserver" – the quarterly Newsletter of the Model A Ford Museum.

Membership – The member handbook will be updated for 2024. If you would like to update photo or text information then contact David Frazee. There was also discussion regarding inclusion of member information on the web under a password protected section.

Hospitality – For now, nothing to report regarding hospitality since the Vista Library does not allow food on the premises.

Tech Report – Mark Greenlee deferred to David Frazee who reviewed a project involving internal milling of a brake drum. David indicated surprise as how involved a seemingly simple process became. He discovered, that in use, the drums get so hot that the walls begin to flare outward. This resulted with the mill affecting the deeper innermost surface but having no affect as it traveled towards the outer flared surface.

Raffle – Karen Beel described slight modification to the raffle process and organized the presentation of a nice variety of gifts. The birthday winner was Anthony Lugo

Meeting adjourned at 6:10 PM.

Submitted by Karla Maxwell

## ***MAFCA PRESIDENT'S MESSAGE***

I am excited to be serving as MAFCA National President for 2024. As a Board of Directors, we are dedicated to serving MAFCA and each of its members ethically and to the best of our ability. Your 2024 Board is dedicated to maintaining MAFCA's long track record of excellence and fiscal responsibility.

Newly elected to the Board this year are Paul Shinn as Technical Director and Bill Truesdell as Advertising Director. Re-elected to their second consecutive term on the Board are Chet Wojcik, Jr. as Marketing and Membership Director and Ed Tolman, Vice-President. Each brings a wealth of business and personal knowledge plus life experiences with them. Along with the new and re-elected members, returning for their second year on the Board are Gary Price as Secretary, Melanie Whittington as Treasurer, Will Langford as Chapter Coordinator and Dave Gill as Publications/Public Relations Director. I look forward to serving with all of these fine representatives this year and learning from their vast experience.

A special thanks to outgoing Board members Kay Lee and Jay McCord for their outstanding service in 2023. 2023 was Kay and Jay's sixth year serving as a Director. We all owe them a round of applause for the dedicated service to MAFCA.

Looking ahead at our calendar of events, we have a wonderful National Convention planned for June in New Mexico. The Southwest Model A SIG is working diligently on making our visit to Ruidoso one to remember. Check them out at [SouthwestAVentures.com](http://SouthwestAVentures.com). Our National Awards Banquet will be held in Salt Lake City, UT in mid-December. Be sure and check out the 2024 NAB Video available via link on the MAFCA website. It is never too early to get these great events on your calendar so don't forget to check out the MAFCA calendar on the MAFCA website. In addition, there will be numerous regional meets that provide wonderful touring and events. Keep an eye on the MAFCA calendars and plan accordingly.

In closing I would like to thank the Santa Maria A's of Santa Maria, CA, Curt Warner, Bill and Laura Hansen, Hank and Karen Haugse, Roberta Weber, Kathy Pedrick, Dave Richards, Jay and Kay McCord and other chapter members for hosting a great 2023 National Awards Banquet. An awesome time was had by all. Thank you all for a wonderful time in Santa Maria, California.

See you down the road.

Robert Bullard, 2024 MAFCA President



## *MEMBERS WE LOST IN JANUARY*



**Larry Beel**

**4/16/1940 to 1/24/2024**

Larry Beel's sudden death has left me as newsletter editor flat footed, as it has many others in the club. There is a need to note his passing in this issue, but my intention is to remember his in the March issue, when we have a chance to compose a proper memorial, so this item is left "To be continued.."

## *FOR SALE*



FOR SALE 1931 Model A Ford Victoria price reduced to \$35,000 or best offer  
Jim King's Victoria has been upgraded to 12 volt

with an overdrive. He wants to offer it to Palomar members before seeing it move out of the area.  
jkrclr@gmail.com 760-937-3588

# DISTRIBUTOR INTRODUCTION

To better understand the role that a distributor plays in the ignition system of a Model A, there are these notes, distilled from an early article by Dale DeKok published in *Model A News*, and then there is a matching quiz on the next page to test your knowledge.

The distributor does exactly as its name implies—distributes the electrical energy to the four cylinders in our engine. As a part of the ignition system, it switches the power supplying the coil's primary windings on and off and routes the coil's high-voltage, output from its secondary windings, to the individual spark plugs according to the firing order of our pistons: 1, 2, 4, 3.

As the crankshaft turns, the connecting rod pulls

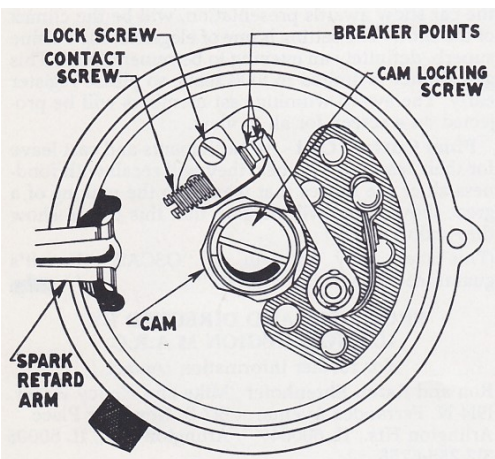

the piston down twice & pushes it up twice. The distributor needs to be timed to provide spark when the piston is about 2 degrees prior to top dead center (TDC)

of that first push. It would not improve performance to “always leave the spark lit” even if that could happen. The proper gas and oxygen mixture (or stoichiometric ratio : 14.7 grams of air to 1 gram of gasoline) needs to be pulled in from the intake manifold, and then compressed within the piston for the spark to have the maximum power stroke, and that is just barely before the highest point possible within the cylinder.

As you can see in the illustration, the distributor's cam, driven off of the crankshaft, has four lobes, one for each cylinder. If it was geared at the same rpms as the crankshaft, it would produce the spark every single time the cylinders reached TDC, so it is geared to turn at one half the RPMs.

The points are pulled closed by a spring, completing the circuit and letting electrons flow. If the point spring is weak, the points will bounce at high RPMs, causing the timing to become erratic and the engine to misfire. A string that's too heavy will promote rapid wear of the rubbing

block and the point gap will decrease with operation. This can soon bring a fall-off in performance.

The distributor high-tension or secondary circuit consists of the rotor and high tension lead from the coil, the cap and body, and of course the spark plug wires. The rotor is mounted on the end of the distributor shaft above the cam and blocking your view of the points. When it's installed with #1 piston two degrees short of TDC, the rotor arm should be in contact with the electrode for #1, about 45 degrees to the right of forward from the driver's perspective.

The rotor is in constant electrical contact with the center contact terminal of the distributor cap by means of a small brush, which in turn is connected to the high-tension lead from the coil. That brush may also wear out and provide an inconsistent flow.

The condenser is another important part of the distributor. It prevents arcing at the breaker points when they are open and it also demagnetizes the coil. When the points open, that collapses the magnetic field, assisted by the condenser. It is fast enough to induce the 20,000 volts within the secondary windings of the coil to jump the spark plug gap and ignite the gasoline. Note that moving from a 6 volt primary system to a 12 volt one does not increase the secondary voltage to 40,000 volts. What it does is provide the same voltage, but taking half of the amps to do it.

A large percentage of condenser trouble can be eliminated by keeping all connections clean and tight. Sand the mounting strap to ensure a ground for the condenser case. Also, keep it as cool as possible. Ford released a heat baffle in late 1929 for use in hot weather to increase their lives.

The breaker plate friction spring should also be sanded bright as that may also ground the points. As said before, an engine that cuts-out or misses may have a weak or rusty friction spring.

Finally, when restoring a distributor, never, never dip the base in paint and never fill or prime the base. It didn't have the same finish as the fenders. This is one case to use a very thin, dull black enamel. On the next page is the quiz. Bonus points for those who can identify which part(s) are missing from the diagram.



# DISTRIBUTOR PART QUIZ

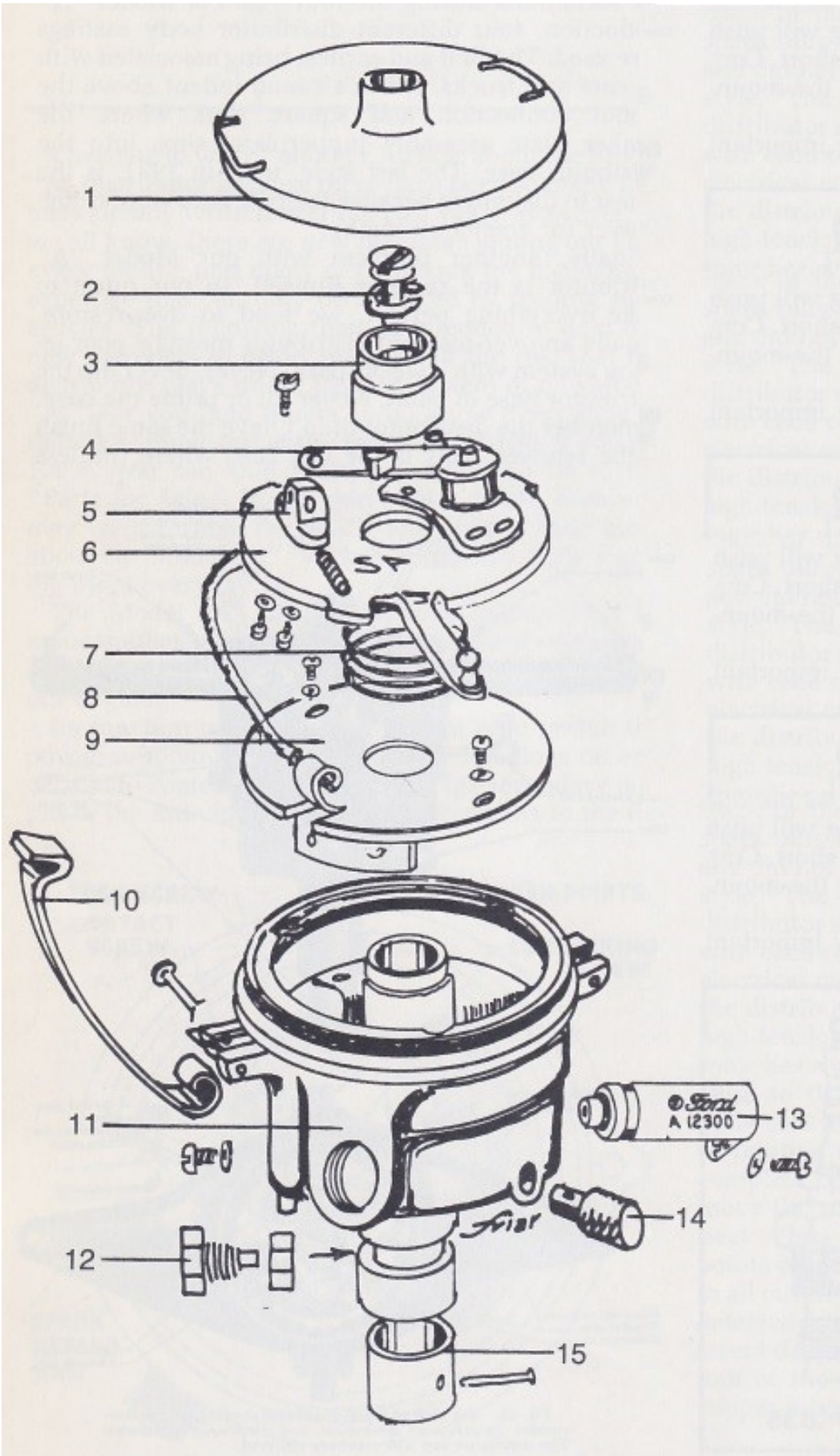

- A. Base Assemble
- B. Base Oiler
- C. Breaker Arm Assembly
- D. Breaker Plate & Insulator Assembly (upper)
- E. Breaker Plate Friction Spring
- F. Bus Bar Support Assembly (lower)
- G. Bus Bar Wire
- H. Cam
- I. Cam Screw & Washer
- J. Cam Shaft Sleeve
- K. Cap
- L. Cap Clamp
- M. Condenser
- N. Contact Screw Bracket
- O. Set Screw & Locking Nut

- 1. \_\_\_\_\_
- 2. \_\_\_\_\_
- 3. \_\_\_\_\_
- 4. \_\_\_\_\_
- 5. \_\_\_\_\_
- 6. \_\_\_\_\_
- 7. \_\_\_\_\_
- 8. \_\_\_\_\_
- 9. \_\_\_\_\_
- 10. \_\_\_\_\_
- 11. \_\_\_\_\_
- 12. \_\_\_\_\_
- 13. \_\_\_\_\_
- 14. \_\_\_\_\_
- 15. \_\_\_\_\_

Bonus \_\_\_\_\_



# Bill Hansen's

Model A Ford Service & Repair  
Proudly using KR Wilson Tools for  
Dealership Quality



14755 Mussey Grade Rd Day 760-789-8296  
Ramona, Ca. 92065 Evenings 619-461-1001  
E-mail lamesla@yahoo.com

**Complete Rebuilding of:** Engine, Transmission,  
Clutch, Rear end, Front End, Steering Box & Brakes.

**Other Services:** Wheel Balancing, Counter Balanced  
Crank Shafts, Engine Babbiting, Lightened Fly-wheels,  
V8 Clutches, Leakless Water Pumps, Carburetors, Dis-  
tributors, Generators, Starters and more.

**CALL FOR COMPLETE LIST OF SERVICES!**



## ARIZONA MODEL A

15838 South Gilbert Road Chandler, Arizona 85225 (480)782-0266

**Business Hours:**

Tuesday - Friday:	. New Parts
9am - 12pm 1pm - 5pm	. Used Parts
Saturday & Evenings:	. Service
Appointment Only!	. Restoration

Owner: Sam Guthrie

**EVERYTHING FROM A TO Z!**



**FREE CATALOG**  
\$10.00 Outside the U.S.



**888-262-5712**  
snydersantiqueauto.com

**THE WORLD'S LARGEST SUPPLIER OF 1909-31 FORD PARTS!**

**Mike's "A" Ford-able Parts**



**Mike Butcher**

124 Model A Drive, Maysville, GA 30558  
email: mike@mikes-afordable.com - www.mikes-afordable.com  
Fax: 706 652 2492 - Phone: 706 652 3866  
1 888 TRY MIKE (879 6453)



*Specialising in 1928 - 1931 Model A Ford Parts*



1928-1948 Ford  
Parts & Accessories

420 W. Chapman Ave. Orange, CA 92866  
Fax: 714-509-1618 • Sales@CWMoss.com  
ebay: stores.ebay.com/CWMossAutoParts

**800-322-1932 • CWMoss.com**



**Steve & Cyndi Mitchell**



**Mitchell MFG.**  
530-458-4500 800-859-2088  
www.mitchelloverdrivemfg.com

MODEL A FORD  
SYNCHRONIZED-TRANSMISSION FORD OVERDRIVES/UNDERDRIVES  
VINTAGE CAR OVERDRIVES 1928-1948

P.O. Box 925 1157 Parker St. Colusa, CA 95932

## BIRTHDAYS

- |                 |        |
|-----------------|--------|
| Nedra Grabowsky | 1 Feb  |
| Anna Velasco    | 5 Feb  |
| Bill Horn       | 8 Feb  |
| Andy Morgosh    | 11 Feb |
| Clyde Marion    | 20 Feb |
| Nancy Quinlan   | 22 Feb |
| Ed Lopez        | 26 Feb |
| Brian Terry     | 26 Feb |

## ANNIVERSARIES

- |              |        |
|--------------|--------|
| Jim and M.A. | 14 Feb |
|--------------|--------|



**800-255-1929 Phone**  
www.brattons.com  
800-774-1930 Fax  
1606 Back Acre Circle  
Mount Airy, MD 21771

*Your source for Quality Model A Ford Parts since 1976*



## ***2024 CALENDAR IN PROGRESS***

January 27-28 (Sat-Sun) 57th TURLOCK SWAP MEET Stanislaus County Fairgrounds in Turlock CA. hosted by Modesto Area A's:

January 28 Last Sunday Breakfast Main St Café, Fallbrook 8 AM

February 7 General Meeting Vista Library 700 Eucalyptus 4:30 PM

February 10 Tour to Mulligan Family Fun Center 24950 Madison Ave Murietta 10:30 @ Pal Estates

February 25 Last Sunday Breakfast J & M's Restaurant 1215 E Valley Pkwy Escondido 8 AM

March 6 General Meeting Vista Library 700 Eucalyptus 4:30 PM

March 8-9 CCRG JAMBOREE Clovis, CA Hosted by Sierra A's  
Very tentative plans are:

March 7 240 miles to Bakersfield  
March 8 114 miles to Clovis  
March 9 Clovis  
March 10 154 miles to Tehachapi  
March 11 196 miles home

March 9 Tour TBD

March 31 Last Sunday Breakfast Village Kitchen & Pie Shop 950 Tamarack Ave Carlsbad 8 AM

April 3 General Meeting Palomar Estates 650 S Rancho Santa Fe 7:00 PM

April 6 Tour TBD

April 14 61st ORANGE COUNTY PANCAKE BREAKFAST Hart Park Orange CA hosted by Orange County Model A's. Cars without overdrives meet at the 76 and I-15 Park and Ride at 6:00 AM, with overdrives at the old Sears parking lot in Carlsbad at 7:30.

April 28 Last Sunday Breakfast San Luis Rey Bakery & Restaurant 490 N El Camino Real 8 AM

May 1 General Meeting Palomar Estates 7:00 PM

May 4 Tour to the 39th Annual Antique Truck Show in Perris at the Southern California Railway Museum 2201 S. A Street Meet at the 76 and I-15 Park and Ride at 8:30 AM

May 26 May Last Sunday Breakfast Golden Egg Omelet House 316 W Mission Ave Escondido followed by a drive up to Fallbrook Car Show at Bates Nut Farm Special 9 AM Meet time.

June 8 Picnic Meeting with Hidden Valley T's and San Diego MAFC at Old Poway Park 14134 Midland Rd Details to follow

June 23-29 SOUTHWEST "A" VENTURES [2024 MAFCA National Convention] Ruidoso NM hosted by Southwest Model A's Info: Raymond Gabaldon, 505.620.0574 - P.O. Box 44 Peralta, NM 87042

June 30 Last Sunday Breakfast Time Out Café 1011 S Santa Fe Ave Vista 8 AM

July 13 Picnic Meeting San Dieguito County Park 1628 Lomas Santa Fe Dr, Del Mar

July 28 Last Sunday Breakfast Swami's Café 101 Encinitas 1163 S Coast Hwy 101 8 AM

August 7 General Meeting Palomar Estates 7:00 PM

August 10 Tour TBD

August 25 Last Sunday Breakfast Money Pit 1360 E Mission Rd San Marcos 8 AM

Last Sunday Breakfasts: September 29 TipTop Meats Carlsbad October 27 Dennys at College and 76 & November 24th Charlie's in Escondido

December 14 Christmas Party and Installation Lunch The Hunter Restaurant 12:00PM

2558 Arroyo Canyon Rd.  
 Escondido, CA 92025  
 Phone: 760-822-9523  
 frazeeintree@hotmail.com

**2024 Board:**

President	<i>David Frazee</i>	760-822-9523	frazeeintree@hotmail.com
Vice President	<i>Bill Adams</i>	760-809-4793	badamsavc@yahoo.com
Treasurer	<i>Bruce Furbush</i>	760-525-9973	bruce.furbush@cox.net
Secretary	<i>Karla Maxwell</i>	760-941-1966	Karlamaxwell@cox.net
Membership Director	Open		
Breakfast Coordinator	Open		
Long Tour Leader	<i>Bruce Howe</i>	858-692-4309	zumaque42@yahoo.com
Short Tour Leader	<i>Mark Greenlee</i>	949-584-0699	markgreenlee@roadrunner.com
<i>Reflector</i> Editor	<i>David Frazee</i>	760-822-9523	frazeeintree@hotmail.com
Pub Relations	<i>Barbara Kruegel</i>	619-981-6523	barb11how@gmail.com
Hospitality	<i>Chuck Grabowsky</i>	760-729-0418	cwgdds@yahoo.com
Librarians	<i>John &amp; Judy Burrell</i>	949-492-4255	jnj.burrellteam@gmail.com
Tech Director	<i>Mark Greenlee</i>	949-584-0699	markgreenlee@roadrunner.com
Entertainment Chair	<i>Karen Beel</i>	760-741-7942	klbeel@sbcglobal.net
Web Master	<i>Rick Spinello</i>	760-703-0965	RickSpinello@gmail.com

**Membership** is \$20 per year and club information, including a membership application and an archive of past newsletters, is available on [www.palomarmodelclub.org](http://www.palomarmodelclub.org)

**Business Meetings** are held the first Wednesday of each month, except June, July, and December, at the Palomar Estates East Clubhouse: 650 S Rancho Santa Fe Rd, in San Marcos at 7:00pm.

Check the website, newsletters, or Facebook group <https://www.facebook.com/groups/palomarmafca> for specifics for the June, July, and December meetings. All Model A Ford hobbyists are welcome.

**The Reflector** is published in Escondido, CA after the 20<sup>th</sup> of each month.

**Palomar Model A Ford Club**



February, 2024

**THE REFLECTOR**

PLEASE  
 PLACE  
 STAMP  
 HERE